



MMXL Series



Models:

MMXL02-D240AC

MMXL05-D240AC

MMXL10-D240AC

MMXL02-D240AC-PCM

MMXL05-D240AC-PCM

MMXL10-D240AC-PCM

User's Manual

Pulse-Width Modulated, Adjustable Speed
Drives for DC Brush Motors

Copyright © 2002 by
Minarik Corporation

All rights reserved. No part of this manual may be reproduced or transmitted in any form without written permission from Minarik Corporation. The information and technical data in this manual are subject to change without notice. Minarik Corporation and its Divisions make no warranty of any kind with respect to this material, including, but not limited to, the implied warranties of its merchantability and fitness for a given purpose. Minarik Corporation and its Divisions assume no responsibility for any errors that may appear in this manual and make no commitment to update or to keep current the information in this manual.

Printed in the United States of America.

Safety Warnings



- This symbol  denotes an important safety tip or warning. Please read these instructions carefully before performing any of the procedures contained in this manual.
- **DO NOT INSTALL, REMOVE, OR REWIRE THIS EQUIPMENT WITH POWER APPLIED.** Have a qualified electrical technician install, adjust and service this equipment. Follow the National Electrical Code and all other applicable electrical and safety codes, including the provisions of the Occupational Safety and Health Act (OSHA), when installing equipment.
- Reduce the chance of an electrical fire, shock, or explosion by proper grounding, over-current protection, thermal protection, and enclosure. Follow sound maintenance procedures.



It is possible for a drive to run at full speed as a result of a component failure. Minarik strongly recommends the installation of a master switch in the main power input to stop the drive in an emergency.

Circuit potentials are at 115 VAC or 230 VAC above earth ground. Avoid direct contact with the printed circuit board or with circuit elements to prevent the risk of serious injury or fatality. Use a non-metallic screwdriver for adjusting the calibration trimpots. Use approved personal protective equipment and insulated tools if working on this drive with power applied.

Contents

Safety Warnings	i
Specifications	1
Dimensions	2
Installation	4
Mounting	4
Wiring	5
Shielding guidelines	6
Heat sinking	7
Line fusing	7
Speed adjust potentiometer	9
Isolation	10
Connections	11
Power, fuse and motor connections	11
Master power switch	11
Motor	12
Power input	12
Line fuse	12
Voltage follower	14
Operation	15
Before applying power	15
Startup	16
Starting and Stopping Methods	17
Line starting and line stopping	17
Automatic restart upon power restoration	18
Inhibit terminals	18

Inhibit plug	19
Decelerating to minimum speed	20
Dynamic braking	21
RUN/BRAKE switch	21
Dynamic brake resistor sizes	21
Calibration	23
Calibration procedure	24
Before applying power	24
MINIMUM SPEED (MIN SPD)	25
MAXIMUM SPEED (MAX SPD)	25
ACCELERATION (ACCEL)	26
DECELERATION (DECEL)	26
REGULATION (IR COMP)	27
CURRENT LIMIT (CURR LIM)	28
Application Notes	34
Multiple fixed speeds	34
Adjustable speeds using potentiometers in series	35
Independent adjustable speeds	36
RUN/JOG switch	37
RUN/JOG option #1	37
RUN/JOG option #2	38
Leader-follower application	39
Single speed potentiometer control of multiple drives (-PCM models only)	40
Reversing	41
Reversing with a DIGI-LOK controller	42

Troubleshooting	43
Before troubleshooting	43
Diagnostic LEDs	44
POWER	44
CURRENT LIMIT (CL/FLT)	44
Replacement Parts	48
Certificate of Compliance	50
CE Certification	50
AC Line Filters	51
Unconditional Warranty	inside back cover

Illustrations

Figure 1. MMXL Dimensions	2
Figure 2. MMXL10 Drive Dimensions With Heat Sink Installed	3
Figure 3. Speed Adjust Potentiometer	9
Figure 4. MMXL Series Connections	13
Figure 5. Voltage Follower Connections	14
Figure 6. Inhibit Terminal Location	19
Figure 7. Run/Decelerate to Minimum Speed Switch	20
Figure 8. Dynamic Brake Connection	22
Figure 9. Calibration Trimpot Layout	23
Figure 10. Approximate CURRENT LIMIT and IR COMP Settings for 120 VAC in, 90 VDC out (actual settings may vary)	30
Figure 11. Approximate CURRENT LIMIT and IR COMP Settings for 120 VAC in, 130 VDC out (actual settings may vary)	31
Figure 12. Approximate CURRENT LIMIT and IR COMP Settings for 240 VAC in, 180 VDC out (actual settings may vary)	32
Figure 13. Approximate CURRENT LIMIT and IR COMP Settings for 240 VAC in, 240 VDC out (actual settings may vary)	33
Figure 14. Multiple Fixed Speeds	34
Figure 15. Adjustable Speeds Using Potentiometers In Series	35
Figure 16. Independent Adjustable Speeds	36
Figure 17. RUN/JOG Option #1	37
Figure 18. RUN/JOG Option #2	38
Figure 19. Leader-Follower Application	39
Figure 20. Single Speed Potentiometer Control of Multiple MMXL-PCM Series Drives	40
Figure 21. Reversing	41
Figure 22. Reversing with a DLC600	42
Figure 23. Diagnostic LED locations	44
Figure 24. MMXL CE Filter Connections	52

Tables

Table 1. Recommended Line Fuse Sizes8
Table 2. Inhibit Plug Part Numbers19
Table 3. Dynamic Brake Resistor Part Numbers22
Table 4. Replacement Parts48
Table 5. AC Line Filters51

Specifications

Model	AC Line Voltage	Max. Continuous Armature Current (Amps DC)	HP Range with 120 VAC Applied	HP Range with 240 VAC Applied
MMXL02-D240AC	120 OR 240	2	1/20 – 1/4	1/10 – 1/2
MMXL05-D240AC	120 OR 240	5	1/4 – 1/2	1/2 – 1
MMXL10-D240AC†	120 OR 240	10†	1/2 – 1	1 – 2

† Requires Minarik heat sink kit p/n 223-0159 above 5 amps

AC Line Voltage 120/240 VAC ± 10%, 50/60 Hz, single phase

Armature Voltage Range

120 VAC input 0-130 VDC

240 VAC input 0 – 240 VDC

Form Factor (at base speed) 1.05

Acceleration/Deceleration Time Range (no load) 0.5 – 6 seconds

Analog Input Voltage Range* [S1(-) to S2(+)] 0 – 5 VDC

Input Impedance (S1 to S2 with 5 VDC input) approximately 70K ohms

Potentiometer Circuit Isolation (-PCM models only) HCPL 7840:2500 VAC

Inhibit Circuit Isolation (-PCM models only) HCPL 0453:2500 VAC

Speed Regulation 1% base speed or better

Ambient Temp. Range (chassis drive) 10°C – 40°C††

†† MMXL 10-D240A C is rated for 10 amps DC max @ 25°C ambient. Derate to 7 amps DC above 25°C.

* Signal must be isolated on non-PCM drives; -PCM drives can use grounded or isolated voltage signal.

Vibration

0.5g max (20 – 50 Hz)

0.1 g max (>50 Hz)

Weight

MMXL02-D240AC 0.66 lb [0.30 kg]

MMXL05-D240AC 0.72 lb [0.32 kg]

MMXL10-D240AC 0.82 lb [0.37 kg]

Dimensions

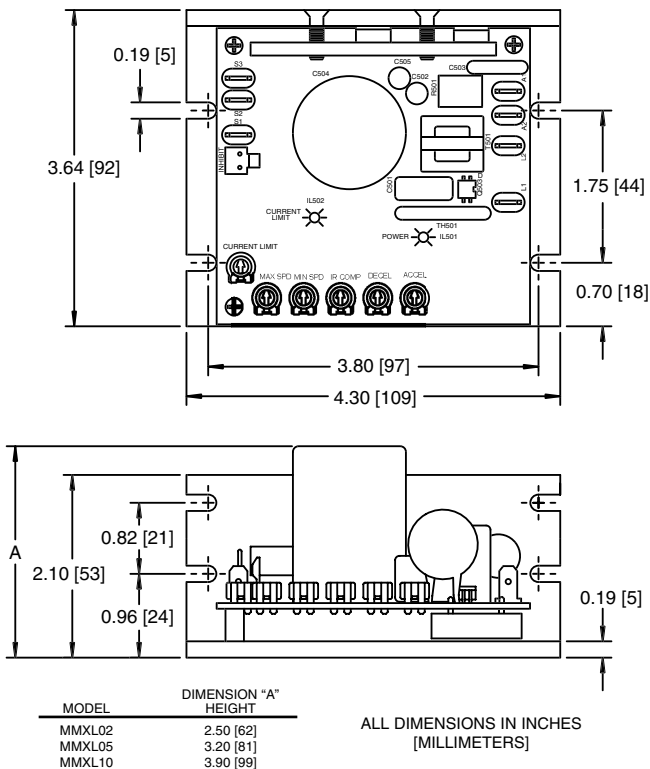
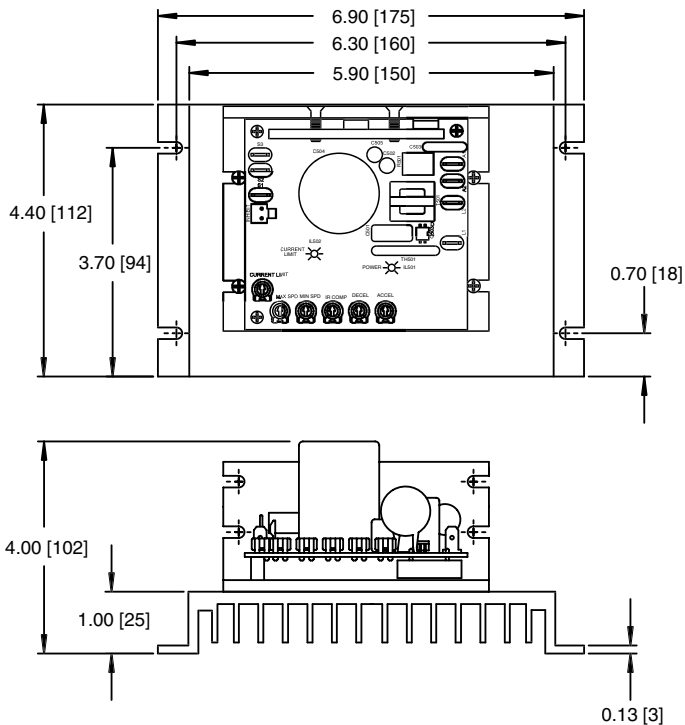

Figure 1. MMXL Dimensions



ALL DIMENSIONS IN INCHES [MILLIMETERS]

Figure 2. MMXL10 Drive Dimensions With Heat Sink Installed

Installation

Mounting



Warning

Do not install, rewire, or remove this control with input power applied. Doing so may cause fire or serious injury. Make sure you have read and understood the Safety Warnings before attempting installation.

- Drive components are sensitive to electrostatic fields. Avoid direct contact with the circuit board. Hold drive by the chassis only.
- Protect the drive from dirt, moisture, and accidental contact.
- Provide sufficient room for access to the terminal block and calibration trimpots.
- Mount the drive away from heat sources. Operate the drive within the specified ambient operating temperature range.
- Prevent loose connections by avoiding excessive vibration of the drive.
- Mount drive with its board in either a horizontal or vertical plane. Six 0.19 in. (5 mm) wide slots in the chassis accept #8 pan head screws. Fasten either the large base or the narrow flange of the chassis to the subplate.

- The chassis must be earth grounded. Use a star washer beneath the head of at least one of the mounting screws to penetrate the anodized chassis surface and to reach bare metal.

Wiring



Warning



Do not install, remove, or rewire this equipment with power applied. Failure to heed this warning may result in fire, explosion, or serious injury.

Circuit potentials are at 115 or 230 VAC above ground. To prevent the risk of injury or fatality, avoid direct contact with the printed circuit board or with circuit elements.

Do not disconnect any of the motor leads from the drive unless power is removed or the drive is disabled. Opening any one motor lead may destroy the drive.

- Use 16–20 AWG wire for speed adjust potentiometer wiring. Use 14–16 AWG wire for AC line (L1, L2) and motor (A1 and A2) wiring.

Shielding guidelines



Warning

Under no circumstances should power and logic leads be bundled together. Induced voltage can cause unpredictable behavior in any electronic device, including motor controls.

As a general rule, Minarik recommends shielding of all conductors.

If it is not practical to shield power conductors, Minarik recommends shielding all logic-level leads. If shielding logic leads is not practical, the user should twist all logic leads with themselves to minimize induced noise.

It may be necessary to earth ground the shielded cable. If noise is produced by devices other than the drive, ground the shield at the drive end. If noise is generated by a device on the drive, ground the shield at the end away from the drive. Do not ground both ends of the shield.

If the drive continues to pick up noise after grounding the shield, it may be necessary to add AC line filtering devices, or to mount the drive in a less noisy environment.

Logic wires from other input devices, such as motion controllers and PLL velocity controllers, must be separated from power lines in the same manner as the logic I/O on this drive.

Heat sinking

Model MMXL10-D240AC requires an additional heat sink (Minarik part number 223–0159) when the continuous armature current is above 5 ADC. All other chassis drives have sufficient heat sinking in their basic configurations.

Apply a thermally conductive heat sink compound (such as Dow Corning® 340 Heat Sink Compound) between the drive chassis and heat sink surface for optimum heat transfer.

Line fusing

Protect all Minarik drives with AC line fuses. Use fast acting AC line fuses rated for 250 volts, and approximately 150% – 200% of the maximum armature current. Fuse only the “hot” side of the AC line (L1) if using 115 VAC line voltage. Do not add line fuses to L1 and L2 unless you use 240 VAC line voltage. See Table 1 on page 8 for recommended line fuse sizes:

Table 1. Recommended Line Fuse Sizes

Maximum Armature Current (DC Amps)	AC Line Fuse Rating (AC Amps)
1.5 and below	3
2.6	5
3.5	8
5.0	10
7.6	15
10	15

Minarik Corporation offers two fuse kits: part number 050-0069 (3-8A Fuse Kit) and 050-0073 (5-20A Fuse Kit). Refer to *Replacement Parts* (page 47) for fuse kit contents.

Speed adjust potentiometer



Warning

Be sure that the potentiometer tabs do not make contact with the potentiometer enclosure. Grounding the input will cause damage to the drive.

Mount the speed adjust potentiometer through a 0.38 in. (10 mm) hole with the hardware provided (Figure 3). Install the circular insulating disk between the panel and the 10K ohm speed adjust potentiometer. Twist the speed adjust potentiometer wire to avoid picking up unwanted electrical noise. If speed adjust potentiometer wires are longer than 18 in. (457 mm), use shielded cable. Keep speed adjust potentiometer wires separate from power leads (L1, L2, A1, A2).

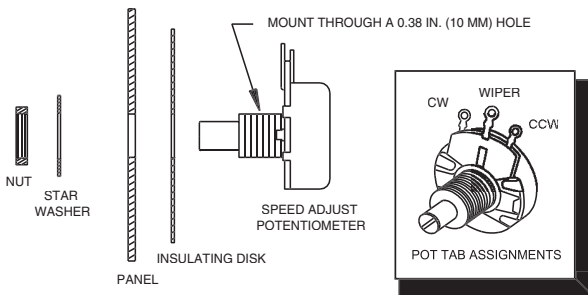

Figure 3. Speed Adjust Potentiometer

Isolation

NOTE: Isolation is incorporated in MMXL-PCM drives only.

The reference circuit (S1, S2 and S3) is optically isolated from the rest of the drive electronics via HCPL7840. It will accept either a grounded or isolated signal reference.

The inhibit input is also optically isolated from the rest of the drive electronics via HCPL0453. It will accept a grounded or isolated bit-type open collector (or switch) input.

Connections



Warning

Do not connect this equipment with power applied.

Failure to heed this directive may result in fire or serious injury.

Minarik strongly recommends the installation of a master power switch in the voltage input line, as shown in Figure 4 (page 13). The switch contacts should be rated at a minimum of 200% of motor nameplate current and 250 volts.

Power, fuse and motor connections

Connect the power input leads, an external line fuse and a DC motor to the drive's printed circuit board (PCB) as shown in Figure 4, page 13.

Master power switch

Decelerating to minimum speed, regenerative braking, or coasting to a stop may not stop a drive that is malfunctioning. Removing AC line power (both L1 and L2) is the only acceptable method for emergency stopping. For this reason, Minarik strongly recommends installing an emergency stop switch on both the L1 and L2 inputs. The switch contacts must be rated at a minimum of 250 volts and 200% of maximum drive current.

Motor

Minarik drives supply motor voltage from A1 and A2 terminals. It is assumed throughout this manual that, when A1 is positive with respect to A2, the motor will rotate clockwise (CW) while looking at the output shaft protruding from the front of the motor. If this is opposite of the desired rotation, simply reverse the wiring of A1 and A2 with each other.

Connect a DC motor to PCB terminals A1 and A2 as shown in Figure 4. Ensure that the motor voltage rating is consistent with the drive's output voltage.

Power input

Connect the AC line power leads to PCB terminals L1 and L2, or to a double-throw, single-pole master power switch (recommended).

Line fuse

Wire an external line fuse between the stop switch (if installed) and the L1 terminal the circuit board. An additional line fuse should be installed on L2 if the input voltage is 230VAC. The line fuse(s) should be rated at 250 volts and 150 - 200% of maximum motor nameplate current. Refer to the line fuse chart on page 8 for fuse ratings.

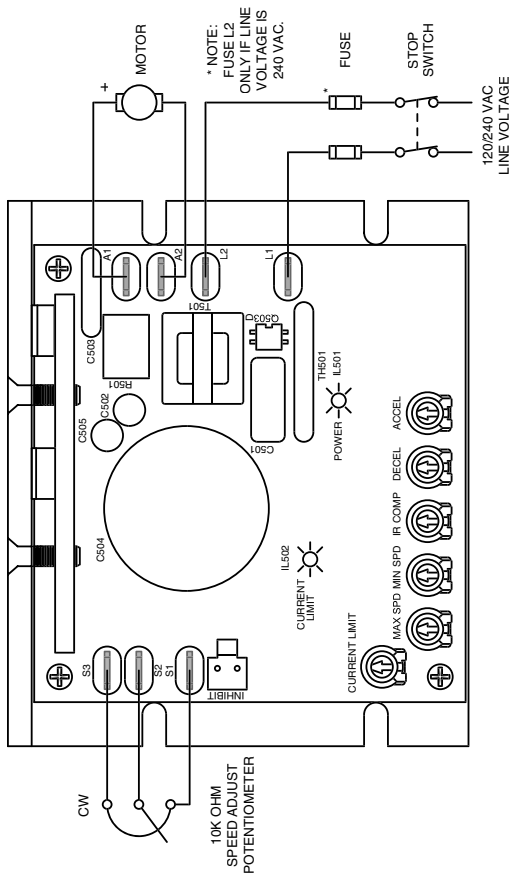

Figure 4. MMXL Series Connections

Voltage follower

Instead of using a speed adjust potentiometer, the drive may be wired to follow a 0 – 5 VDC grounded* or isolated voltage signal (Figure 5). Connect the signal return (–) to S1. Connect the signal high or (+) to S2. Make no connection to S3. A potentiometer can be used to scale the analog input voltage.

** Refers to MMXL -PCM models only.*

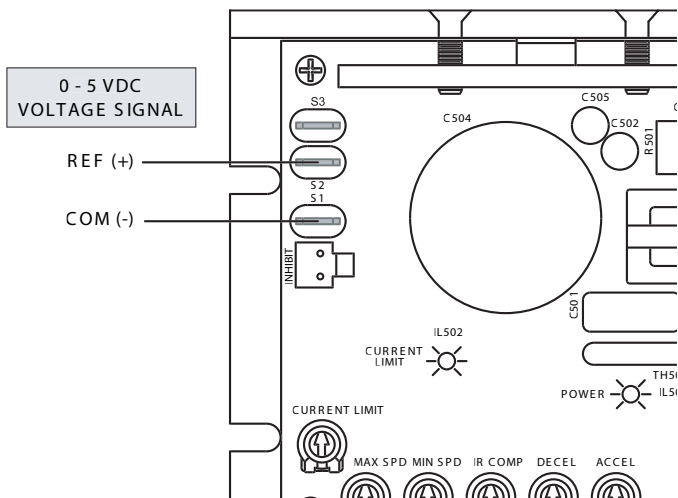

Figure 5. Voltage Follower Connections

Operation



Warning



Dangerous voltages exist on the drive when it is powered, and up to 30 seconds after power is removed and the motor stops. BE ALERT. High voltages can cause serious or fatal injury. For your safety, use personal protective equipment (PPE) when operating this drive.

If the motor or drive does not perform as described, disconnect the AC line voltage immediately. Refer to the Troubleshooting section on page 39 for further assistance.

Before applying power

- Verify that no conductive material is present on the printed circuit board.

Startup

To start the drive:

1. Turn the speed adjust potentiometer full counterclockwise (CCW). If the drive is following a voltage signal, set the voltage signal to 0 VDC.
2. Apply AC line voltage.
3. Slowly advance the speed adjust potentiometer clockwise (CW). If the drive is following a voltage signal, slowly increase the voltage signal. The motor slowly accelerates as the potentiometer is turned CW, or the voltage signal is increased. Continue until the desired speed is reached.
4. Remove AC line voltage from the drive to coast the motor to a stop.

Starting and Stopping Methods



Warning

Decelerating to minimum speed, regenerative braking, or coasting to a stop is recommended for frequent starts and stops. Do not use any of these methods for emergency stopping. They may not stop a drive that is malfunctioning. Removing AC line power (both L1 and L2) is the only acceptable method for emergency stopping.

For this reason, **Minarik strongly recommends installing an emergency stop switch on both the L1 and L2 inputs** (see *Connections* on page 13).

Frequent decelerating to minimum speed or regenerative braking produces high torque. This may cause damage to motors, especially gearmotors that are not properly sized for the application.

Line starting and line stopping

Line starting and line stopping (applying and removing AC line voltage) is recommended for infrequent starting and stopping of a drive only. When AC line voltage is applied to the drive, the motor accelerates to the speed set by the speed adjust potentiometer. When AC line voltage is removed, the motor coasts to a stop.

Automatic restart upon power restoration

All drives automatically run to set speed when power is applied and the drive is enabled. The drive will accelerate at a rate controlled by the ACCEL trimpot. Refer to the Calibration section for information on adjusting this setting.

Inhibit terminals



Warning

Inhibit is used for frequent starts and stops. It must never be used as an emergency stop because it may not stop a drive that is malfunctioning. Removing AC power (L1 and L2) is the only acceptable method for emergency stopping.

Jumper the inhibit terminals to coast the motor to a stop (Figure 6). Remove the jumper to accelerate the motor to set speed.

The inhibit terminals on MMXL-PCM model drives are optically isolated from the drive electronics. The user may apply a simple switch closure or an open-collector input, which may be isolated or non-isolated.

Inhibit plug

Minarik Corporation offers two accessory plug harnesses for use with the inhibit terminals:

Table 2. Inhibit Plug Part Numbers

Minarik®	
Part Number	Description
201-0024	Inhibit plug with 18-in. (46 cm) wires
201-0079	Inhibit plug with 36-in. (91 cm) wires

Twist inhibit plug wires and separate them from other power-carrying wires or sources of electrical noise. Use shielded cable if the inhibit plug wires are longer than 18 inches (46 cm). If shielded cable is used, ground only one end of the shield to earth ground. Do not ground both ends of the shield.

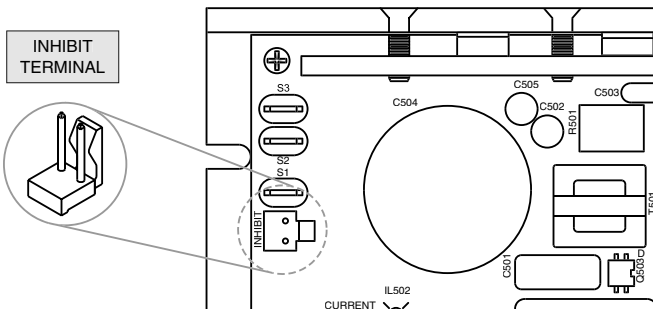

Figure 6. Inhibit Terminal Location

Decelerating to minimum speed

A switch may be used to decelerate the motor to minimum speed. Connect the switch as shown in Figure 7. Close the switch between S1 and S2 to decelerate the motor from set speed. Open the switch to accelerate the motor to set speed. The ACCEL and DECEL trimpot settings determine the rate at which the motor accelerates and decelerates, respectively.

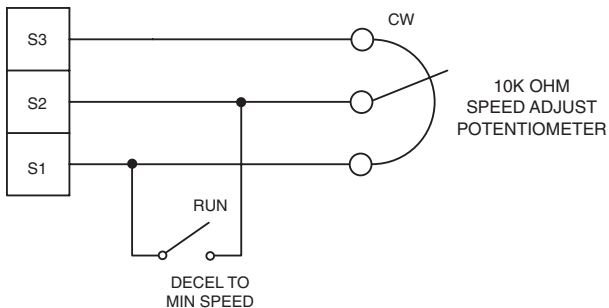

Figure 7. Run/Decelerate to Minimum Speed Switch

Dynamic braking



Warning

Wait for the motor to come to a complete stop before setting the RUN/BRAKE switch to RUN. This will prevent high armature currents from damaging the motor or drive.

Dynamic braking may be used to rapidly stop a motor (see Figure 8 on page 22). For the RUN/BRAKE switch, use a double-pole, double throw switch rated for at least the maximum DC armature voltage and maximum braking current.

RUN/BRAKE switch

Install a double-pole, double-throw switch between the INHIBIT terminals and a dynamic brake resistor as shown in Figure 8 on page 22. Set the switch to the BRAKE position to dynamically brake the motor to a stop. Set the switch to the RUN position to accelerate the motor to set speed at a rate controlled by the ACCEL trimpot.

Dynamic brake resistor sizes

Size the dynamic brake resistor according to the motor current rating (refer to Table 3 on page 22). The dynamic brake resistance listed in the table is the smallest recommended resistance allowed to prevent possible demagnetization of the motor. The motor stops less rapidly with higher brake resistor values.

Table 3. Dynamic Brake Resistor Part Numbers

Minimum Motor Armature Current Rating	Minimum Dynamic Brake Resistor Value	Dynamic Brake Resistor Wattage
Less than 2 ADC	1 ohm	1W
2–3 ADC	5 ohm	5W
3–5 ADC	10 ohm	10W
5–10 ADC	20 ohm	20W
10–17 ADC	40 ohm	50W

For motors rated 1/17 horsepower and lower, a brake resistor is not necessary since the armature resistance is high enough to stop the motor without demagnetization. Replace the dynamic brake with 12 gauge wire.

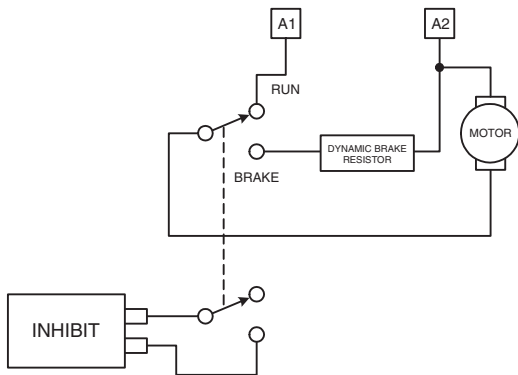
**Figure 8. Dynamic Brake Connection**

Calibration

Each drive is factory calibrated to its maximum current rating. Readjust the calibration trimpot settings to accommodate lower current motors.

All adjustments increase with CW rotation, and decrease with CCW rotation. Use a non-metallic screwdriver for calibration. Each trimpot is identified on the printed circuit board.

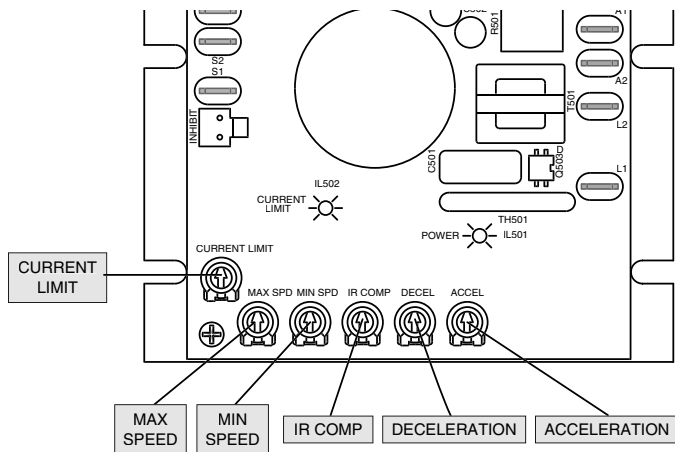

Figure 9. Calibration Trimpot Layout

Calibration procedure

Before applying power

1. Verify that no conductive material is present on the printed circuit board.
2. Set all trimpots full except CURRENT LIMIT full counterclockwise (CCW).
3. Set the CURRENT LIMIT trimpot full clockwise (CW).
4. Set the speed adjust potentiometer or input signal to zero speed.
5. Set the INHIBIT switch to INHIBIT, or install the jumper between the INHIBIT terminals of SO501.
6. Apply line voltage to the drive. The green POWER LED shall light, but the motor should remain stopped.
7. Set the INHIBIT switch to ENABLE, or remove the jumper between the INHIBIT terminals of SO501.

MINIMUM SPEED (MIN SPD)

MIN SPD determines the minimum speed when the speed adjust potentiometer is turned full CCW. It is factory set to zero speed. To calibrate MIN SPD:

1. Set the speed adjust potentiometer full CCW.
2. Adjust the MIN SPD trimpot until the motor turns at the desired minimum speed.

MAXIMUM SPEED (MAX SPD)

The MAX SPD setting determines the maximum motor speed when the speed adjust potentiometer is turned full CW. It is factory set for maximum rated motor speed. To calibrate MAX SPD:

1. Set the MAX trimpot full CCW.
2. Turn the speed adjust potentiometer full CW.
3. Adjust the MAX SPD trimpot until the desired maximum motor speed is reached.

ACCELERATION (ACCEL)

The ACCELERATE setting determines the time the motor takes to ramp to a higher speed. See **Specifications** on page 1 for approximate acceleration times. The ACCELERATE setting is factory set to its minimum value (full CCW).

Turn the ACCEL trimpot CW to increase the acceleration time and CCW to decrease the acceleration time.

DECELERATION (DECEL)

The DECELERATE setting determines the time the motor takes to ramp to a lower speed. See Specifications on page 1 for approximate deceleration times. The DECELERATE setting is factory set to its minimum value (full CCW).

Turn the DECEL trimpot CW to increase the deceleration time and CCW to decrease the deceleration time.

REGULATION (IR COMP)

The IR COMP setting determines the degree to which motor speed is held constant as the motor load changes. It is factory set for optimum motor regulation. Recalibrate the IR COMP setting when using a lower current rated motor. Refer to Figures 10 - 13 (pp 29 - 32) for typical IR COMP settings, or recalibrate using the following procedure:

If the motor does not maintain set speed as the load changes, gradually rotate the IR COMP trimpot CW. If the motor oscillates (overcompensation), the IR COMP trimpot may be set too high (CW). Turn the IR COMP trimpot CCW to stabilize the drive.

CURRENT LIMIT (CURR LIM)



Warning

Although the current limit trimpot can be set to exceed the motor's maximum armature current rating, Minarik recommends you do not run the motor continuously beyond that rating. Continuous operation beyond the maximum armature current rating may cause thermal degradation of the motor and drive.

The CURRENT LIMIT setting determines the maximum torque for accelerating and driving the motor. CURRENT LIMIT is factory set at 120% of maximum drive current. You must recalibrate the CURRENT LIMIT setting if using a lower current rated motor. Refer to Figures 10 - 13 (pp 29 - 32) for typical CURRENT LIMIT settings.

1. With no power applied to the drive, connect a DC ammeter in series with the motor armature.
2. Set the CURRENT LIMIT trimpot to full CCW.
3. Carefully lock the motor armature. Ensure that the motor is firmly mounted.
4. Apply line power. The motor should be stopped.
5. Set the speed potentiometer or reference signal to maximum speed. The motor should remain stopped.

CURRENT LIMIT (cont.)

6. Slowly rotate the CURRENT LIMIT trimpot clockwise (CW) until the ammeter reads 120% of maximum motor armature current.
7. Set the speed adjust potentiometer or reference signal to zero speed.
8. Remove power from the drive.
9. Remove the lock from the motor shaft.
10. Remove the ammeter in series with the motor armature.

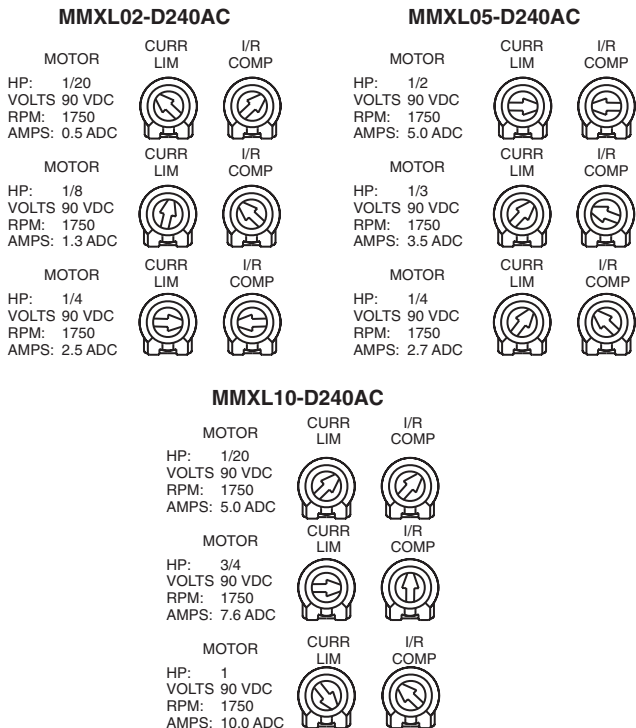

Figure 10. Approximate CURRENT LIMIT and IR COMP Settings for 120 VAC in, 90 VDC out (actual settings may vary)

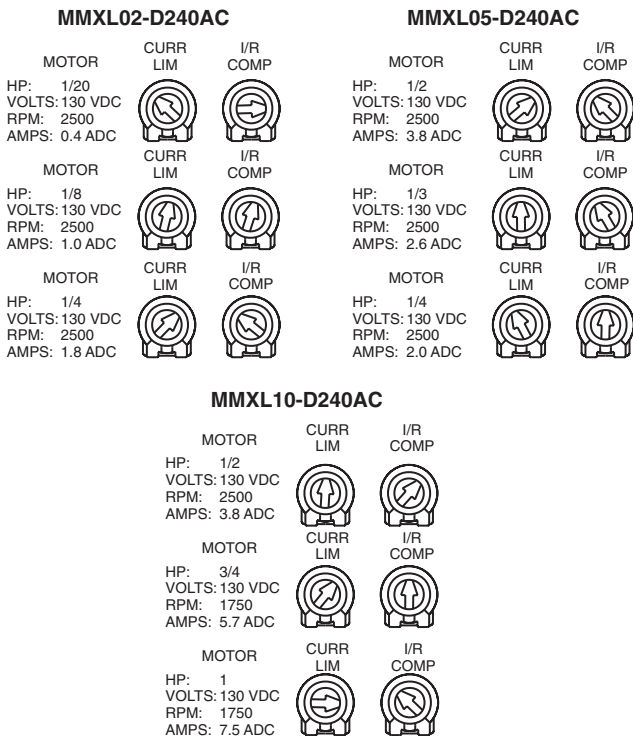

Figure 11. Approximate CURRENT LIMIT and IR COMP Settings for 120 VAC in, 130 VDC out (actual settings may vary)

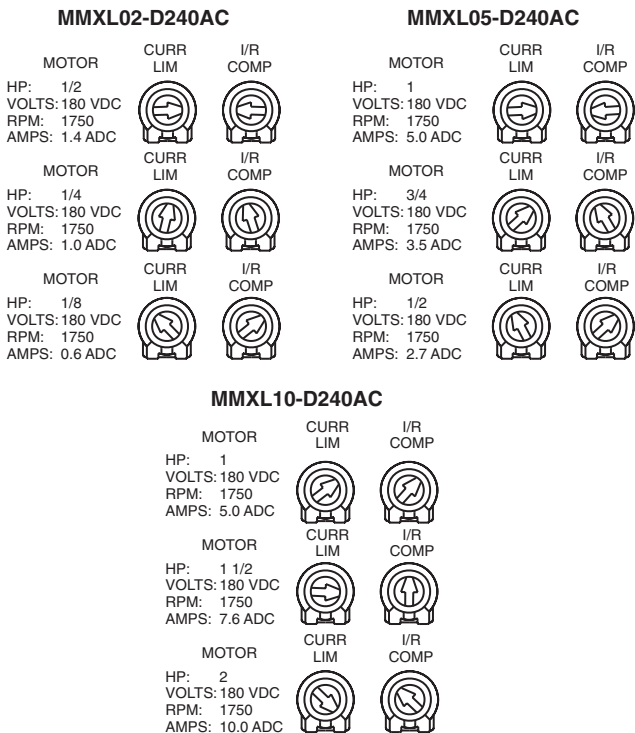

Figure 12. Approximate CURRENT LIMIT and IR COMP Settings for 240 VAC in, 180 VDC out (actual settings may vary)

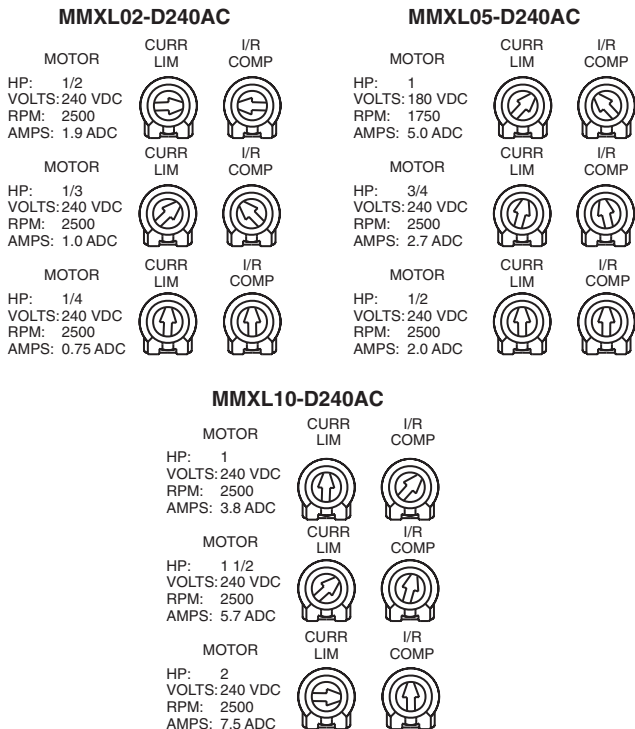

Figure 13. Approximate CURRENT LIMIT and IR COMP Settings for 240 VAC in, 240 VDC out (actual settings may vary)

Application Notes

Multiple fixed speeds

Replace the speed adjust potentiometer with series resistors having a total series resistance of 10 K ohms (Figure 14). Add a single pole, multi-position switch with the correct number of positions for the desired number of fixed speeds.

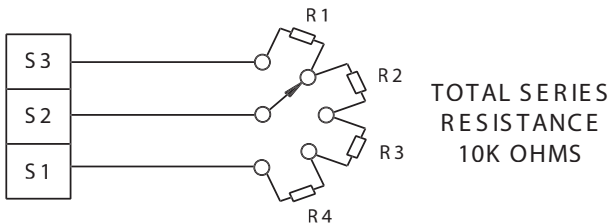

Figure 14. Multiple Fixed Speeds

Adjustable speeds using potentiometers in series

Connect two speed adjust potentiometers as shown in Figure 15 to select between multiple forward speeds.

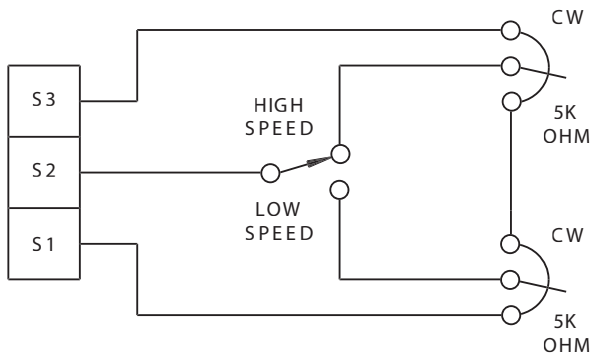

Figure 15. Selectable Speeds Using Potentiometers In Series

Independent adjustable speeds

Connect two speed adjust potentiometers with a single-pole, multi-position switch and two or more potentiometers in parallel, with a total resistance of 10K ohms. Figure 16 shows the connection of two independent speed adjust potentiometers that can be mounted at two separate operating stations.

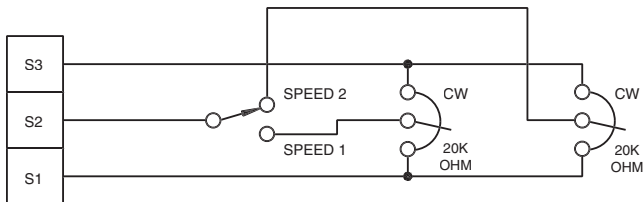

Figure 16. Independent Adjustable Speeds

RUN/JOG switch

Using a RUN/JOG switch is recommended in applications where quick stopping is not needed and frequent jogging is required. Use a single pole, two position switch for the RUN/JOG switch, and a single-pole, normally-closed, momentary operated pushbutton for the JOG pushbutton.

RUN/JOG option #1

In option #1 (Figure 17), connect the RUN/JOG switch and the JOG pushbutton to the INHIBIT terminals. When the RUN/JOG switch is set to JOG, the motor coasts to minimum speed. Press the JOG pushbutton to jog the motor. Return the RUN/JOG switch to RUN for normal operation.

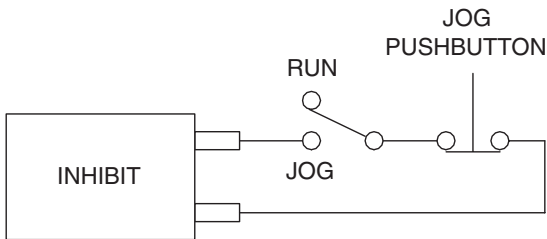

Figure 17. RUN/JOG Option #1

RUN/JOG option #2

In option #2, connect the RUN/JOG switch to the speed adjust potentiometer using a single-pole, two-position switch for the RUN/JOG switch, and a single-pole, normally-closed, momentary operated pushbutton for the JOG pushbutton as shown in Figure 18. When the RUN/JOG switch is set to JOG, the motor decelerates to minimum speed. Press the JOG pushbutton to jog the motor. Return the RUN/JOG switch to RUN for normal operation.

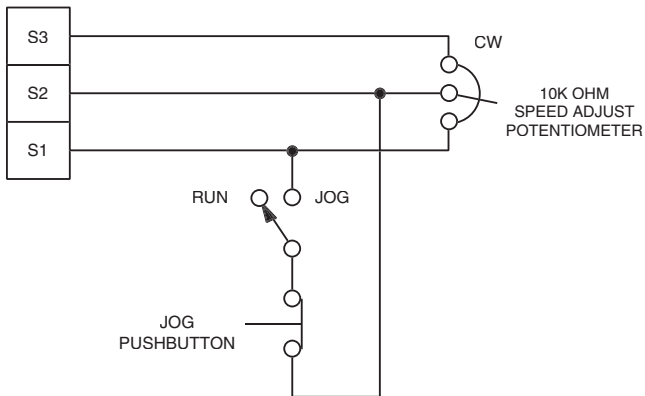

Figure 18. RUN/JOG Option #2

Leader-follower application

In this application, use a PCM4 to monitor the speed of the leader motor (Figure 19). The PCM4 outputs a voltage proportional to the leader motor armature voltage. The follower drive uses this voltage reference to set the speed of the follower motor. An optional ratio potentiometer may be used to scale the PCM4 output voltage.

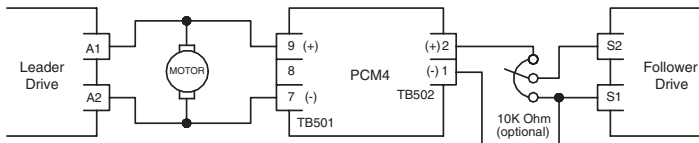

Figure 19. Leader-Follower Application

Single speed potentiometer control of multiple drives (-PCM models only)

Because the potentiometer circuit is optically isolated from the drive circuitry, the inputs may be tied together. Up to eight (8) drives can be controlled with a single speed adjust potentiometer (see Figure 20 below).

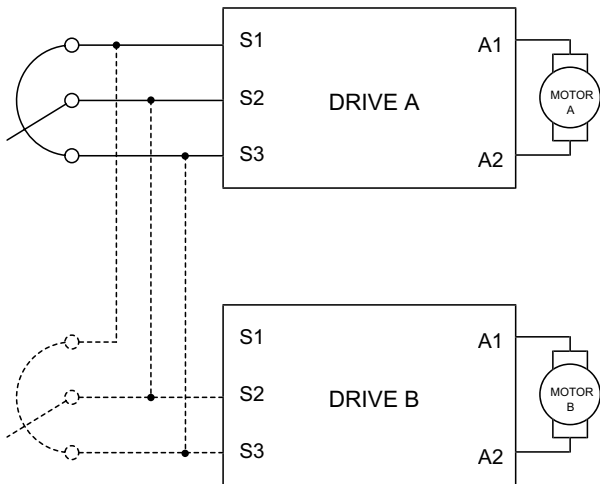

Figure 20. Single Speed Potentiometer Control of Multiple MMXL-PCM Series Drives

Reversing

A dynamic brake may be used when reversing the motor direction (Figure 21). Use a three-pole, three-position switch rated for at least the maximum DC armature voltage and maximum braking current. Wait for the motor to stop completely before switching it to either the forward or reverse direction. See the *Dynamic braking* section on page 21 for sizing the dynamic brake resistor.

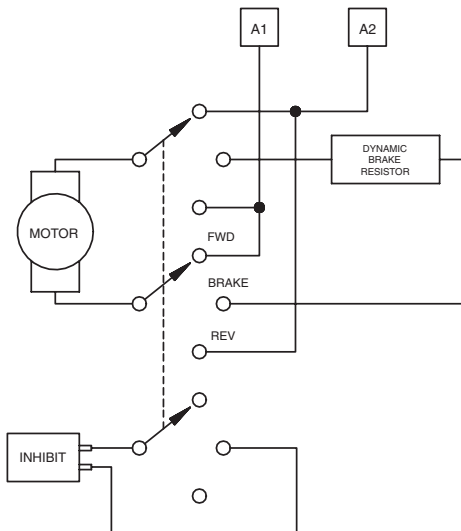

Figure 21. Reversing

Reversing with a DIGI-LOK controller

A DIGI-LOK controller, model DLC600, can be used in a reversing application (Figure 22). The controller must be inhibited while braking. Without the inhibit feature, the controller will continue to regulate, causing overshoot when the DIGI-LOK is switched back to the drive.

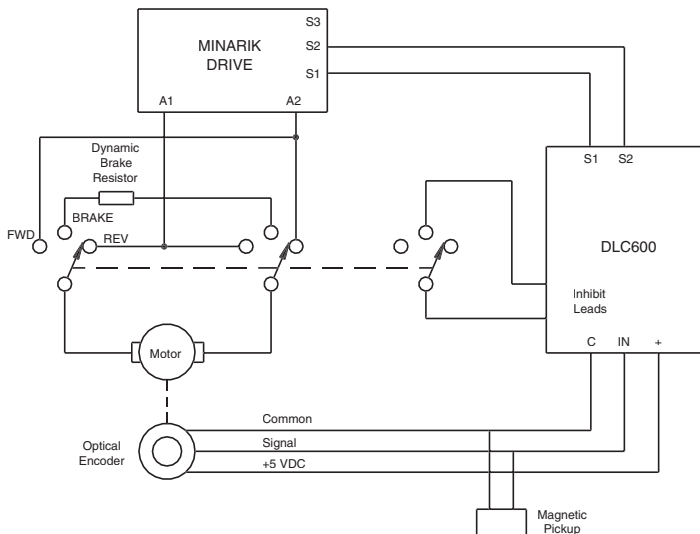

Figure 22. Reversing with a DLC600

Troubleshooting



Warning

Dangerous voltages exist on the drive when it is powered, and up to 30 seconds after power is removed. When possible, disconnect the drive while troubleshooting. High voltages can cause serious or fatal injury.

Before troubleshooting

Perform the following steps before starting any procedure in this section:

- Disconnect AC line voltage from the drive.
- Check the drive closely for damaged components.
- Check that no conductive or other foreign material has become lodged on the printed circuit board.
- Verify that every connection is correct and in good condition.
- Verify that there are no short circuits or grounded connections.
- Check that the voltage selection switch settings match the AC line and output voltages.
- Check that the drive's rated armature and field outputs are consistent with the motor ratings.

For additional assistance, contact your local Minarik distributor, or the factory direct: Phone: 1-800-MINARIK (646-2745) or
Fax: 1-800-394-6334

Diagnostic LEDs

MMXL series drives are equipped with the following diagnostic LEDs to aid in troubleshooting or monitoring equipment status. Refer to Figure 23 below.

POWER

Green LED lights when AC line voltage is applied to the drive.

CURRENT LIMIT (CL/FLT)

Red LED lights when drive output current exceeds the threshold set by the CURRENT LIMIT trimpot.

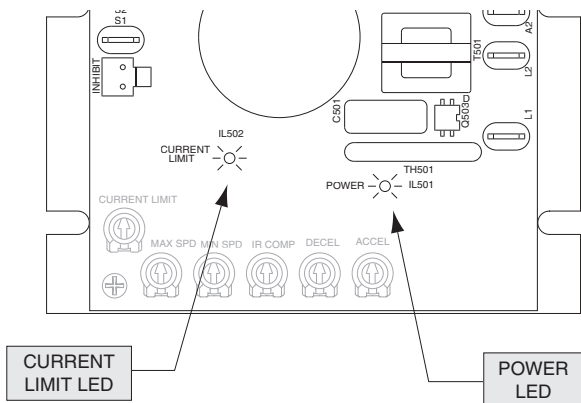

Figure 23. Diagnostic LED locations

Symptom	Possible Causes	Suggested Solutions
Line fuse blows	<ol style="list-style-type: none"> 1. Line fuses are the wrong size. 2. Motor cable or armature is shorted to ground. 3. Nuisance tripping caused by a combination of ambient conditions and high-current spikes. 	<ol style="list-style-type: none"> 1. Check that line fuses are the proper size. 2. Check motor cable and armature for shorts. 3. Add a blower to cool the drive components; decrease CURRENT LIMIT settings, or resize motor and drive for actual load demand, or check for incorrectly aligned mechanical components or “jams”. See page 27 for information on adjusting the CURRENT LIMIT trimpot.
Line fuse does not blow, but the motor does not run	<ol style="list-style-type: none"> 1. Reference signal or speed adjust pot is set to zero speed. 2. Reference signal or speed adjust potentiometer connections are open. 	<ol style="list-style-type: none"> 1. Increase reference signal or speed adjust potentiometer setting. 2. Check that the reference signal or speed adjust potentiometer connections are not open.

Symptom	Possible Causes	Suggested Solutions
Line fuse does not blow, but the motor does not run (cont.)	<ol style="list-style-type: none"> 3. Drive is overloaded. 4. Drive is not receiving AC line voltage. 5. Motor is not connected. 	<ol style="list-style-type: none"> 3. Verify that the motor is not jammed. Increase CURRENT LIMIT setting (page 27). 4. Apply AC line voltage to L1 and L2. 5. Connect motor to A1 and A2.
Motor runs too fast at maximum speed setting	<ol style="list-style-type: none"> 1. MIN SPD and MAX SPD settings are too high. 	<ol style="list-style-type: none"> 1. Recalibrate MIN SPD (page 24) and MAX SPD (page 25).
Motor runs too slow or too fast	<ol style="list-style-type: none"> 1. MIN SPD and MAX SPD are not calibrated. 	<ol style="list-style-type: none"> 1. Recalibrate MIN SPD (page 24) and MAX SPD (page 25).
Motor will not reach the desired speed.	<ol style="list-style-type: none"> 1. MAX SPD setting is too low. 2. IR COMP setting is too low. 3. Motor is overloaded. 	<ol style="list-style-type: none"> 1. Increase MAX SPD setting (page 25). 2. Increase IR COMP setting (page 26). 3. Check motor load. Resize the motor if necessary.

Symptom	Possible Causes	Suggested Solutions
Motor pulsates or surges under load	<ol style="list-style-type: none"><li data-bbox="351 225 578 273">1. IR COMP is set too high.<li data-bbox="351 356 586 405">2. Control is in current limit mode.	<ol style="list-style-type: none"><li data-bbox="655 225 936 326">1. Adjust the IR COMP setting slightly CCW until the motor speed stabilizes (page 26).<li data-bbox="655 356 912 510">2. Check that motor and drive are of sufficient horsepower and amperage. You may need to replace the motor and/or the drive.

Replacement Parts

Replacement parts are available from Minarik Corporation and its distributors for this drive series.

Table 4. Replacement Parts

Model No.	Symbol	Description	Minarik P/N
MMXL02-D240AC	C504	470 mF, 400 V Capacitor	011-0120
	D501	16 A, 600V Diode	071-0044
	Q502	Power MOSFET	070-0085
	Q503	Power MOSFET	070-0083
	R501	0.1 ohm, 5 W Resistor	032-0100
	T501	Transformer TSD1017	230-0108
		10 Kohm Potentiometer Kit	202-0066
MMXL05-D240AC	C504	680 mF, 400 V Capacitor	011-0080
	D501	16 A, 600V Diode	071-0044
	Q502	Power MOSFET	070-0085
	Q503	Power MOSFET	070-0083
	R501	0.1 ohm, 5 W Resistor	032-0100
	T501	Transformer TSD1017	230-0108
		10 Kohm Potentiometer Kit	202-0066
MMXL10-D240AC	C504	1000 mF, 400 V Capacitor	011-0089
	D501	16 A, 600V Diode	071-0044
	Q502	Power MOSFET	070-0086
	Q503	Power MOSFET	070-0083
	R501	0.01 ohm, 5 W Resistor	032-0129
	T501	Transformer TSD1017	230-0108
		10 Kohm Potentiometer Kit	202-0066

FUSE KIT CONTENTS**3 - 8A FUSE KIT (050-0069)**

- 3 AMP 3AG Fast-Acting Fuse (2 ea)
- 5 AMP 3AG Fast-Acting Fuse (2 ea)
- 8 AMP 3AG Fast-Acting Fuse (2 ea)
- 1/2A Pico Fuse (1 ea)

5 - 20A FUSE KIT (050-0073)

- 5 AMP 3AG Fast-Acting Fuse (2 ea)
- 8 AMP 3AG Fast-Acting Fuse (2 ea)
- 10 AMP 3AB Normal-blo Fuse (2 ea)
- 5 AMP 3AB Normal-blo Fuse (2 ea)
- 20 AMP 3AB Normal-blo Fuse (2 ea)
- 1/2A Pico Fuse (1 ea)

POTENTIOMETER KIT CONTENTS (202-0066)

- 10k ohm \pm 5%, 5W Potentiometer (1 ea)
- 3/8-32 X 1/2 Nut (1 ea)
- Potentiometer Insulating Washer (1 ea)
- Non-insulated 1/4-inch Female Tab (7 ea)

Certificate of Compliance

CE Certification

Minarik Corporation hereby certifies that its MMXL series drives, including the MMXL-PCM series, have been approved to bear the CE" mark provided the conditions of approval have been met by the end user.

The OEM must meet the following conditions:

- All wires, including logic, AC power and motor leads, must be shielded. Do not ground both ends of the shield.
- The MMXL motor control module must be enclosed in a solid metal enclosure. The enclosure lid, body and backplane must all be tied to a low-impedance earth ground.
- A VV-series Corcom© filter (or equivalent) must be wired into the AC main. (See Table 5 on page 50.)
- The ground connection between the shielded cable, installed line filter and metal enclosure must be wired to solid earth ground (resistance less than 500 ohms), not machine ground. This is **very important!**



Compliance allows Minarik's MMXL series to bear the CE mark.

The end user, as described herein, falls into one of two categories:

1. The Consumer will deploy a stand-alone unit as an integral, yet external, portion of the machine being operated.
2. The Original Equipment Manufacturer (OEM) will implement the product as a component of the machine being manufactured.

AC Line Filters

In addition to EMI/RFI safeguards inherent in the MMXL series' design, external filtering is required. To meet CE approval conditions, use the line filters (or equivalent) listed in Table 5. Connect the filter as shown in Figure 24.

Table 5. AC Line Filters

Drive	AC Current	Corcom Filter
MMXL02	3A	6VV1
MMXL05	7A	10VV1
MMXL10	12A	20VV1

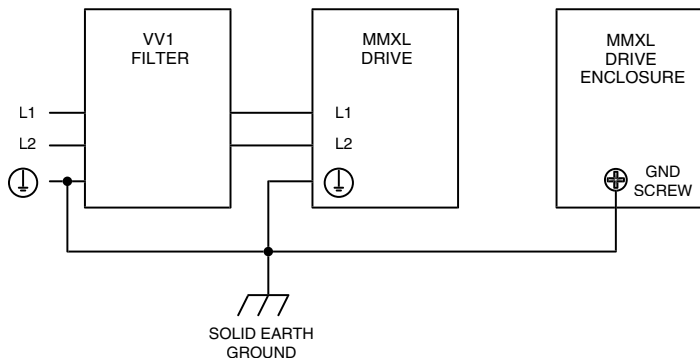

Figure 24. MMXL CE Filter Connections

Unconditional Warranty

A. Warranty - Minarik Corporation (referred to as “the Corporation”) warrants that its products will be free from defects in workmanship and material for twelve (12) months or 3,000 hours, whichever comes first, from date of manufacture thereof. Within this warranty period, the Corporation will repair or replace, at its sole discretion, such products that are returned to Minarik Corporation, 901 East Thompson Avenue, Glendale, CA 91201-2011 USA.

This warranty applies only to standard catalog products, and does not apply to specials. Any returns for special controls will be evaluated on a case-by-case basis. The Corporation is not responsible for removal, installation, or any other incidental expenses incurred in shipping the product to and from the repair point.

B. Disclaimer - The provisions of Paragraph A are the Corporation’s sole obligation and exclude all other warranties of merchantability for use, express or implied. The Corporation further disclaims any responsibility whatsoever to the customer or to any other person for injury to the person or damage or loss of property of value caused by any product that has been subject to misuse, negligence, or accident, or misapplied or modified by unauthorized persons or improperly installed.

C. Limitations of Liability - In the event of any claim for breach of any of the Corporation’s obligations, whether express or implied, and particularly of any other claim or breach of warranty contained in Paragraph A, or of any other warranties, express or implied, or claim of liability that might, despite Paragraph B, be decided against the Corporation by lawful authority, the Corporation shall under no circumstances be liable for any consequential damages, losses, or expense arising in connection with the use of, or inability to use, the Corporation’s product for any purpose whatsoever.

An adjustment made under warranty does not void the warranty, nor does it imply an extension of the original 12-month warranty period. Products serviced and/or parts replaced on a no-charge basis during the warranty period carry the unexpired portion of the original warranty only.

If for any reason any of the foregoing provisions shall be ineffective, the Corporation’s liability for damages arising out of its manufacture or sale of equipment, or use thereof, whether such liability is based on warranty, contract, negligence, strict liability in tort, or otherwise, shall not in any event exceed the full purchase price of such equipment.

Any action against the Corporation based upon any liability or obligation arising hereunder or under any law applicable to the sale of equipment or the use thereof, must be commenced within one year after the cause of such action arises.



14300De La Tour Drive
South Beloit, IL 61080

Tel: (800) MINARIK (646-2745)

Fax: (800) 394-6334

www.minarikcorp.com

Document number 250-0252, Revision 7

Printed in the U.S.A - 08/07